

Stainless Steel Drive-Point Piezometers

Model 615

The Model 615 Drive-Point Piezometer is designed as an affordable method to monitor shallow groundwater and soil vapor in suitable conditions.

The Drive-Points attach to inexpensive 3/4" (20 mm) NPT steel drive pipe which is widely available through local plumbing and hardware stores.

Solinst Drive-Point Piezometers are most often installed as permanent well points. They can also be used for short term monitoring applications.

High quality samples can be obtained if polyethylene or Teflon® lined tubing is attached to the stainless steel drive point. Groundwater sampling and hydraulic head measurements can be taken within the tubing using small diameter equipment, as described overleaf.

Solinst Drive-Point Piezometers can be driven into the ground with any direct push or drilling technology, including the Manual Slide Hammer shown at right. To avoid clogging or smearing of the screen during installation, a shielded version is also available.



Installing Piezometers with a Manual Slide Hammer



[Get Quote](#) | [More Info](#)

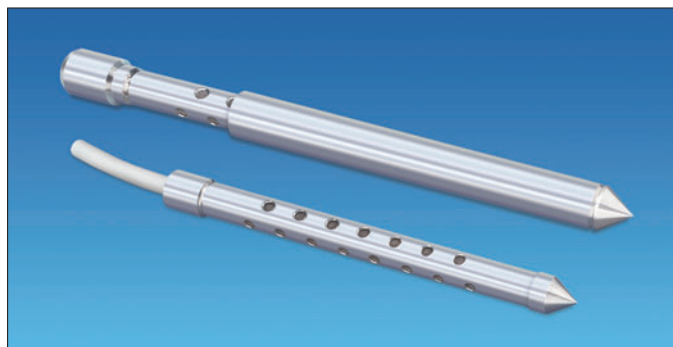

Model 615 Drive-Point and Shielded Drive-Point Piezometer

Applications

- Groundwater sampling, including VOCs
- Water level monitoring
- Base flow monitoring in stream beds
- Contaminant plume delineations
- Soil gas sampling
- UST monitoring
- Low cost and minimal disturbance site assessment
- Sparge points

High Quality Samples

The Model 615 Piezometer has a stainless steel, 50 mesh cylindrical filter-screen, within a 3/4" (20 mm) stainless steel drive-point body, screen support and a barbed fitting for attachment of sample tubing. Optional heavy-duty extension couplings are also available to create a strengthened and more rugged piezometer.

The inner barbed fitting allows connection of 5/8" OD x 1/2" ID (16 mm x 12 mm) LDPE or Teflon sample tubing. This prevents sample water from contacting the steel extension rods, and maintains high sample integrity, even when inexpensive carbon steel extensions are used.

Ideal for soil vapor sampling. Where an air-tight connection is most desirable, the compression fitting option allows users to attach 1/4" (6 mm) sample tubing directly to the top of the screened portion of the drive-point.

The 615 S shielded drive-point has a single use, 1-1/2" (38 mm) dia. shield to avoid smearing and plugging of the screen during installation. The strengthened connector at the top of the drive-point acts as an annular seal, which avoids contamination from higher levels in the hole.

The 615 N, designed without a tubing barb, is to be used for water level measurements. This saves money and provides better access for Water Level Meters.



Sampling Within Narrow Diameters

Direct push sampling has quickly become a popular way to obtain groundwater samples. However, sampling within drive-points requires a narrow diameter sampler. Solinst offers several options for this specific sampling application.

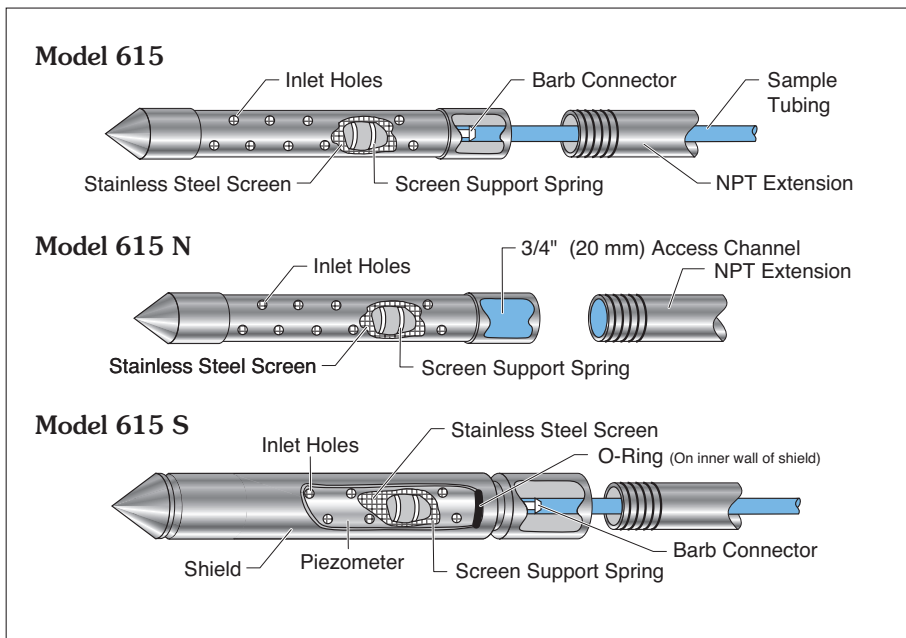

Peristaltic Pump, Model 410

The Peristaltic Pump uses the suction lift principle. Suitable for 1/4" (6 mm) ID or larger diameters. The Peristaltic Pump provides a regulated and steady flow. It works effectively up to 33 ft. (10 m) at sea level.

Inertial Pump, Model 404

The Inertial Pump consists of a check valve and tubing. It is raised and lowered to lift a sample. The SS10 foot valve suits wells as narrow as 1/2" (12 mm) ID and works to depths of 74 ft. (25 m).

Miniature Point Source Bailer, Model 429

The 1/2" (12 mm) dia. stainless steel bailer works very well in the 615 N. The bottom emptying device permits a regulated, steady flow.

Hydraulic Head

Water levels can be measured in any of the drive-points described, using a Solinst Model 101 Water Level Meter, or Model 102 or 102M Mini Laser Marked Coaxial Cable Water Level Indicator for the most accurate hydraulic head measurements.

Manual Slide Hammer

For the most inexpensive wellpoint installations, the Manual Slide Hammer can be used to install the Solinst Drive-Point Piezometers. The 25lb (11Kg) slide hammer and all other equipment can easily be transported in a car or truck to most sites.

A heavy duty drive head is used, on which the slide hammer impacts, and a tubing by-pass ensures that the tubing does not get damaged during installation.

Couplings

Heavy duty couplings are available for the Model 615 Drive-Point Piezometers. The reinforced shoulder gives added support to the pipe threads, to withstand driving stresses and to give more accurate alignment. The maximum OD is 1.5" (38 mm).

Depth Limitations

Drive-point piezometers are not suitable for all sites. The depth limitations vary, especially with soil conditions and the drive method used.

